



Rolling Shutters and Rolling Grilles SB, TGT and DD

Technical Manual: Issue 01.04.2016



Abbreviations Used

ABP	= Lockable bottom profile
BB	= Panel width
BH	= Panel height
BMB	= Door width ordering size
BMH	= Door height ordering size
DHV	= Loss of passage height
DIF	= Difference dimension
ET	= Fitting depth
ET_{AW}	= Fitting depth with horizontal operator
EZS	= Lintel trap guard
F_{horiz}	= Horizontal force at the fixing point
F_{vert}	= Vertical force at the fixing point
FS	= Sideroom for side guide
KU	= Support bracket dimension bottom
L	= Bearing side sideroom
L_{AR}	= Bearing side sideroom with additional posts
LDB	= Clear passage width
LDH	= Clear passage height
LF	= Structural opening
L_{PV}	= Bearing side sideroom for curtain cover
LZ	= Clear frame dimension
LWB	= Structural opening width
M_{PV}	= Motor side sideroom for curtain cover
MS	= Motor side sideroom for direct drive operators
MS_{AR}	= Motor side sideroom for direct drive operators with additional posts
OFF	= Top edge of finished floor
PS	= Side space requirement
PV	= Curtain cover
RAM	= Overall frame dimension
S	= Required headroom:
S_B	= Height of fascia panel
SD	= Lintel seal
SKS	= Closing edge safety device
SPV	= Required headroom for doors with curtain cover
S_{SBP}	= Required headroom for door with chamfered bottom profile
UB	= Bottom edge actuation
UB_{VDD}	= Bottom edge actuation with VDD
VDD	= Operator cover DD
WLK	= Wind load class acc. to EN 12424

Dissemination as well as duplication of this document and the use and communication of its content are prohibited unless explicitly permitted. Noncompliance will result in damage compensation obligations. All rights reserved in the event of patent, utility model or design model registration. Subject to changes.

Note:

All dimensions in this document provide the minimum details in [mm] and are standard values (If necessary, please request the accurate values from Hörmann KG Dissen).

Table of Contents

Topic	Page
Abbreviations used	2
Contents	3
Profile overview	4
Arrangement of the windows and ventilation grilles	6
Fitting space for controls / operator data	7
Side Door NT 60	8
Chamfered bottom profile	10
Rolling shutters SB / rolling grilles SB	
Space requirements	12
Table of standard values / maximum wind loads	13
Side guide / lintel seal	14
Support bracket / maximum load at the fixing point	15
Actuation types	16
Trap guard PVSB / loss of passage height	17
Rolling shutters TGT / rolling grilles TGT	
Space requirements	18
Table of standard values / side guide / lintel seal / support bracket / maximum load at the fixing point / loss of passage height	19
Rolling shutters DD / rolling grilles DD	
Space requirements	20
Space requirements behind the lintel	21
Guide rail	22
Lintel seals / support brackets / maximum loads at the fixing point	23
Weld-on plates for support brackets / fitting in the opening with additional posts	24
Break-in-resistant locks / maximum wind loads	25
Trap guard / curtain cover PVDD without VDD	26
Trap guard / curtain cover PVDD with VDD	27
Table of standard values	28
Decotherm S	28
Decotherm S with accessory package S6	30
HR 120 S	32
HR 120 A	34
HR 120 aero	36
HR 116 A	38
HG-L	40
HG-V	42
HG-S	44

Profile Overview

Decotherm

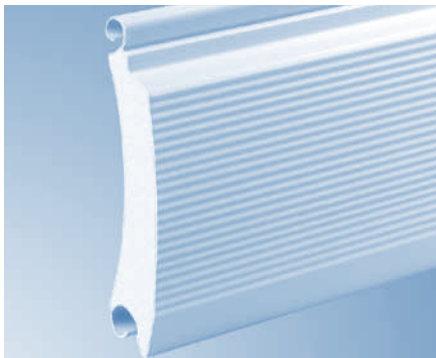

Decotherm

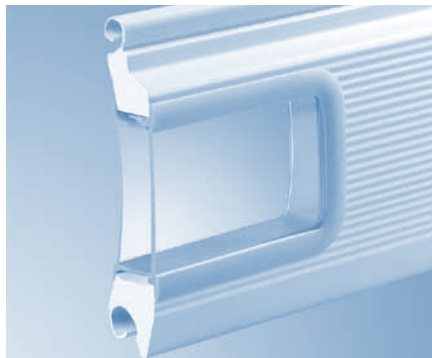

Decotherm with rectangular window

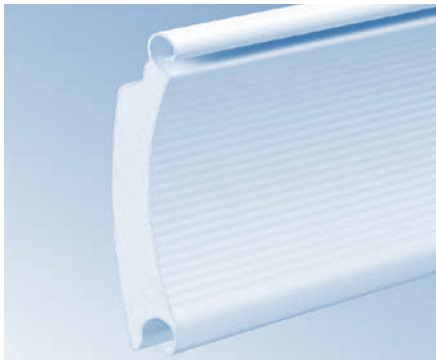

Decotherm external rolling shutters

Profile data Decotherm S

- Material: 0.34 mm steel
- Profile height: 109 mm
- Assembly dimensions for panels and infills:
 - 1st profile: 109 mm
 - Each further profile: 96 mm
- Profile weight/m²: Approx. 10.3 kg
- Thermal insulation: U = 3.9 W/(m²·K)
- Fire behaviour: Class E (DIN EN 13501-1)

HR 120

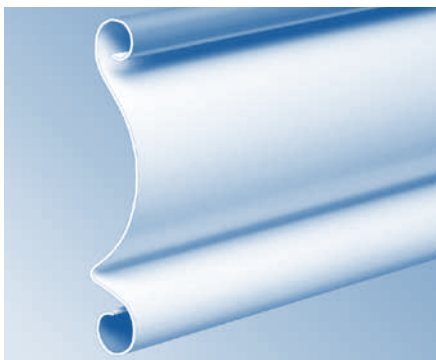

HR 120

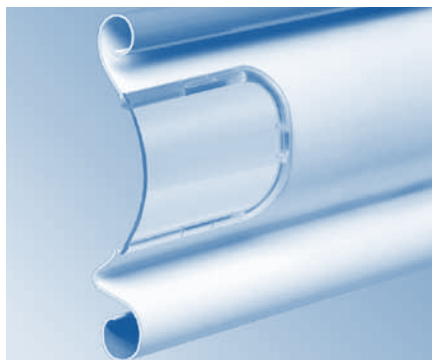

HR 120 with window

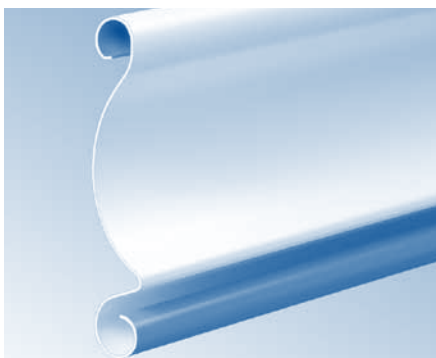

HR 120, external rolling shutters

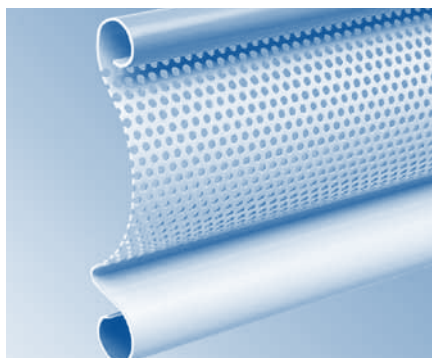

HR 120 aero

Profile data HR 120

- Material:
 - HR 120 A: 1.0 mm aluminium
 - HR 120 aero: 1.0 mm aluminium
 - HR 120 S: 1.0 mm steel
- Profile height: 119 mm
- Assembly dimensions for panels and infills:
 - 1st profile: 119 mm
 - Each further profile:
 - HR 120 A: 102.7 mm
 - HR 120 aero: 102.7 mm
 - HR 120 S: 102.5 mm
- Profile weight/m²:
 - HR 120 A: Approx. 6 kg
 - HR 120 aero: Approx. 5.5 kg
 - HR 120 S: Approx. 15 kg
- Thermal insulation: -
- Building materials class: A2 (DIN 4102)

Note for HR 120 aero:

- Free ventilation cross section approx. 30 % of the door surface
- External rolling shutter only in a bright-rolled version

HR 116

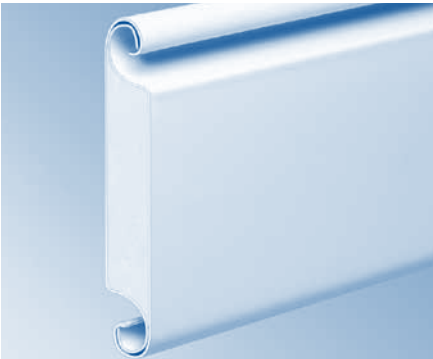

HR 116, internal and external rolling shutters

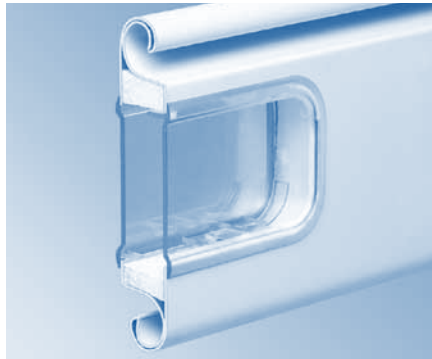

HR 116 with window

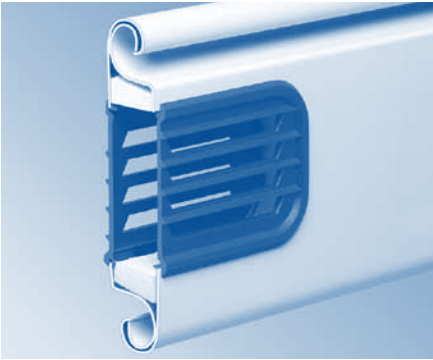

HR 116 with ventilation grille

Profile data HR 116 A

- Material: 1.0 mm aluminium
- Profile height: 119 mm
- Assembly dimensions for panels and infills:
 - 1st profile: 119 mm
 - Each further profile: 103.6 mm
- Profile weight/m²: Approx. 10 kg
- Thermal insulation: U = 5.3 W/(m²·K)
- Building materials class: B2 (DIN 4102)
- Free ventilation cross section approx. 2350 mm² per ventilation grille

Rolling grilles

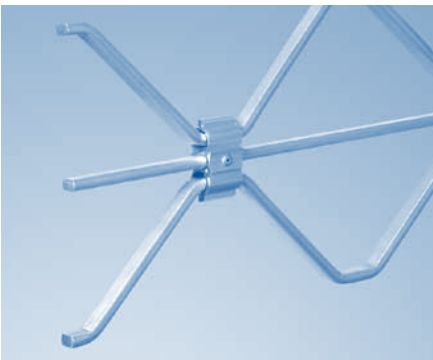

HG-L



HG 75

Profile data HG-L, HG 75

- | | HG-L | HG 75 |
|--|-----------|--------|
| • Material | Aluminium | |
| • Profile height | 80 mm | 84 mm |
| • Assembly dimensions for panels and infills: | | |
| – 1st profile | 80 mm | 84 mm |
| – Each further profile | 97.5 | 75.0 |
| • Curtain weight kg/m ² | 6.5 | 6.7 |
| • Free ventilation cross section of the door surface | 77 % | 37.5 % |



HG-V, HG-S

Profile data HG-V, HG-S

- Material:
 - HG-V: Aluminium / stainless steel
 - HG-S: Galvanized steel
- Profile height: 60 mm
- Assembly dimensions for panels and infills:
 - 1st profile: 60 mm
 - Each further profile: 68.5 mm

- | | Curtain weight/m ² | Material thickness | Door width |
|--------|-------------------------------|--------------------|------------|
| • | | | |
| – HG-V | Approx. 7 kg | 16 × 4 | ≤ 3500 mm |
| | Approx. 8 kg | 20 × 4 | > 3500 mm |
| – HG-S | Approx. 14 kg | 16 × 4 | ≤ 4000 mm |
| | Approx. 15 kg | 18 × 4 | ≤ 6000 mm |
| | Approx. 16 kg | 20 × 4 | > 6000 mm |
- Free ventilation cross section approx. 85 % of the door surface

Arrangement of the Windows and Ventilation Grilles

Decotherm S

Standard window version

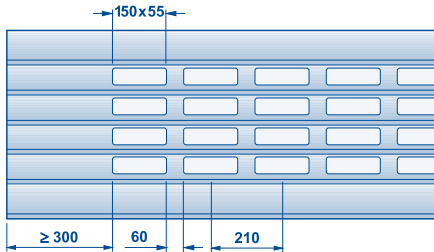

Note:

- Window profiles reduce the resistance to wind load
- Maximum 8 window profiles
- Maximum 4 window profiles for rolling shutters SB and TGT with door width ≤ 2000 mm
- Minimum door width 1245 mm
- Edge spacing with accessory package S6 ≥ 500 mm

Window logistics version

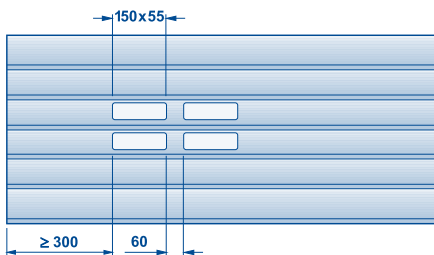

Note:

- 2 profiles with 2 window elements on the left and right
- Minimum door width 1245 mm

HR 120 S / A

Standard window version

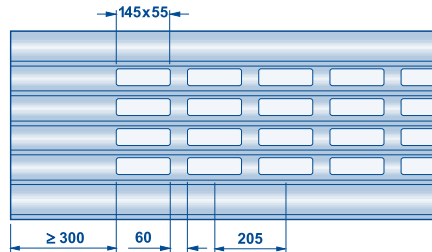

Note:

- Window profiles reduce the resistance to wind load
- Maximum 8 window profiles
- Maximum 4 window profiles for rolling shutters SB with door width ≤ 2000 mm
- Minimum door width 1750 mm

Window logistics version

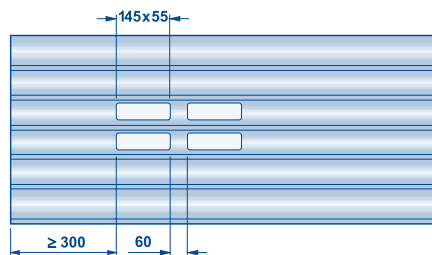

Note:

- 2 profiles with 2 window elements on the left and right
- Minimum door width 1750 mm

HR 116 A

Standard window version

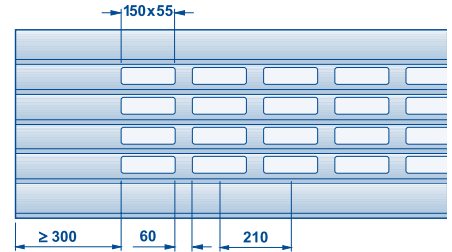

Note:

- Window profiles reduce the resistance to wind load
- Minimum door width 1750 mm
- Maximum number of window profiles:

Door width	Number of window profiles
≤ 6000	Max. 20 profiles
> 6000	Max. 15 profiles
> 8000	Max. 10 profiles
> 10000	Max. 5 profiles

Window logistics version

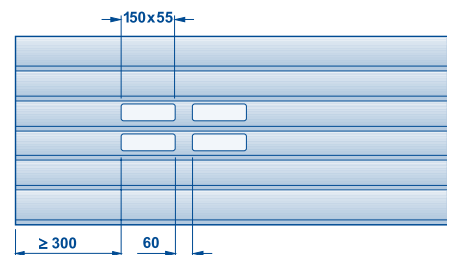

Note:

- 2 profiles with 2 window elements on the left and right
- Minimum door width 1750 mm

Ventilation grilles

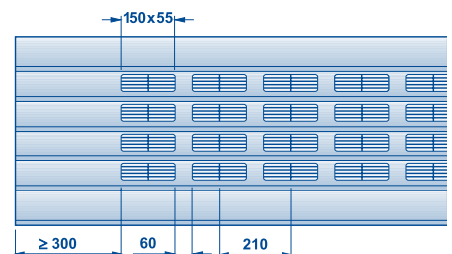

Note:

- Minimum door width 1750 mm
- Maximum number of ventilation grille profiles:

Door width	Number of ventilation grille profiles
≤ 6000	Max. 20 profiles
> 6000	Max. 15 profiles
> 8000	Max. 10 profiles
> 10000	Max. 5 profiles

Fitting Space for Controls / Operator Data

Fitting space for controls

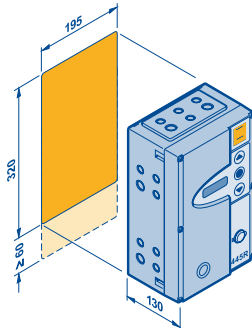

300, 360, 445R, B 455 R, 460 R

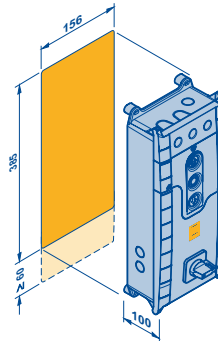

B 971 R S6

Operator data

Operator designation		Direct drive operators								
		DD17	DD25	DD25 WS	DD30	DD30	DD30	DD40	DD50	DD65
Output torque	Nm	170	250	250	300	300	300	400	500	650
Safety catch torque	Nm	510	635	635	635	635	635	890	1070	1400
Test no.		Door FV 4/024	Door FV 4/024	Door FV 4/025	Door FV 4/025	Door FV 4/025	Door FV 4/025	Door FV 4/025	Door FV 4/025	Door FV 4/025
Revolutions at the barrel	min ⁻¹	15	15	15	15	15	15	15	15	15
Motor power	kW	0.40	0.55	0.75	0.85	0.85	0.85	0.85	0.75	1.10
Operating voltage	V	3 × 400	3 × 400	1 × 230	3 × 230	3 × 400	3 × 500	3 × 400	3 × 400	3 × 400
Frequency	Hz	50	50	50	50	50	50	50	50	50
Motor rated current	A	5.24	2.3	8.0	4.4	2.55	2.25	2.55	2.95	4.2
Temperature range	°C	-20/+40	-20/+40	-20/+40	-20/+40	-20/+40	-20/+40	-20/+40	-20/+40	-20/+40
Continuous sound pressure level	dB(A)	< 70	< 70	< 70	< 70	< 70	< 70	< 70	< 70	< 70
Protection category	IP	65	65	65	65	65	65	65	65	65
Door cycles (Open + Close)	h ⁻¹	10	10	10	10	10	10	10	10	10
	d ⁻¹	150	150	150	150	150	150	150	150	150

Operator designation		Direct drive operators						WA		
		DD100	DD160	DD180	DD17.60	DD25.60	DD40.40	250 R S4	300 R S4	300 AR S4
Output torque	Nm	1000	1600	1800	170	250	400	11	11	11
Safety catch torque	Nm	2800	3125	3125	837	1020	1020	--	--	--
Test no.		14-003305-PR01	14-003305-PR01	14-003305-PR01	Door FV 4/024	Door FV 04/025	Door FV 04/025	--	--	--
Revolutions at the barrel	min ⁻¹	10	7	6	8–60	10–60	9–40	12	15	15
Motor power	kW	1.30	1.30	1.30	0.85	1.5	1.5	0.25	0.25	0.25
Operating voltage	V	3 × 400	3 × 400	3 × 400	1N-230 ¹⁾	1N-230 ¹⁾	1N-230 ¹⁾	1 × 230	1 × 230	1 × 230
Frequency	Hz	50	50	50				50/60	50/60	50/60
Motor rated current	A	6.5	6.5	6.5	6.6	7.3	7.3	6.0	6.0	6.0
Temperature range	°C	-10/+40	-10/+40	-10/+40	+5/+40	+5/+40	+5/+40	-20/+60	-20/+60	-20/+60
Continuous sound pressure level	dB(A)	< 70	< 70	< 70	< 70	< 70	< 70	< 70	< 70	< 70
Protection category	IP	65	65	65	65	65	65	65	65	20 ³⁾
Door cycles (Open + Close)	h ⁻¹	10	10	10	30	20	15	5	10 ²⁾	10
	d ⁻¹	150	150	150	300	300	300	75	150 ²⁾	150

1) Neutral conductor (N) required

2) Maximum number of door cycles for rolling shutters/rolling grilles TGT: 20 per hour or 300 per day

3) In combination with PVSB: IP 44

Side Door NT 60

Possible handing options

Fitting in the opening

Fitting next to the door, opening outwards or inwards, RH or LH hinged



Fitting in the opening, opening inwards or outwards, RH or LH hinged

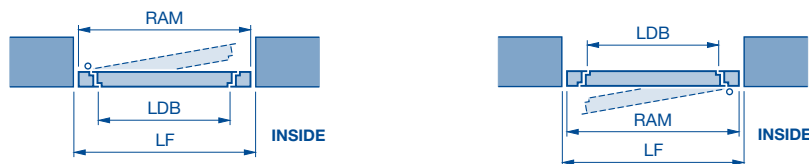

Overall frame dimensions

	Ordering width	Ordering height	Size range width	Size range height
Side door	$RAM = LF - 20$	$RAM = LF - 10$	770 – 1300	1865 – 2525
Aluminium fascia profile	$RAM = LF - 20$	$RAM = LF - 10$	770 – 1300	360 – 5800

Note:

- Doors with multiple-point locking: ordering height $RAM \geq 1940$ mm
- Doors with rolling grille infill HG 75: size range width = 931 – 1300 mm
- Aluminium fascia panels above 5800 mm height are delivered in two parts.

Clear passage dimensions

Opening angle	Width (LDB)	Height (LDH)
136°	$RAM - 149$	$RAM - 70$
90°	$RAM - 194$	$RAM - 70$

Fitting dimensions

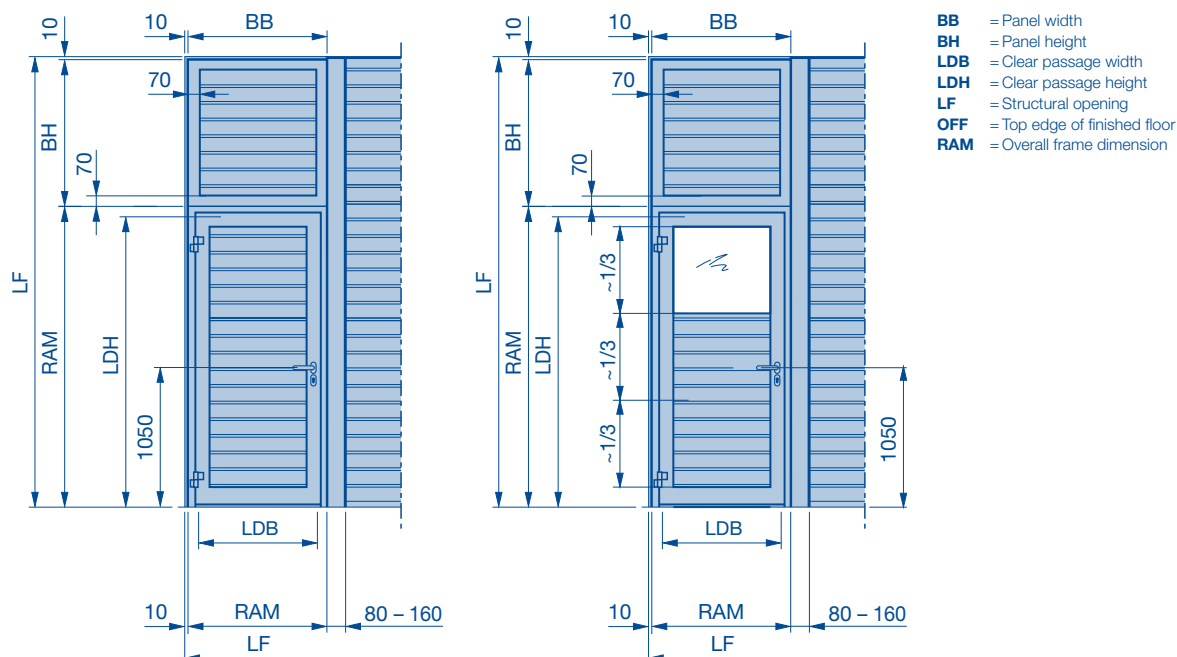

Possible fitting types

Door in the opening

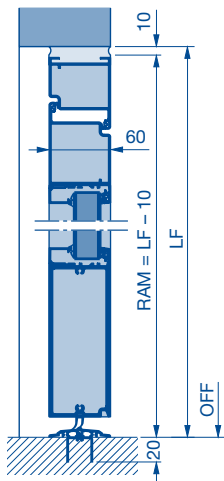

Door with aluminium fascia panel in the opening

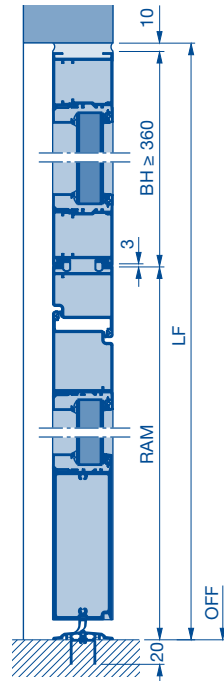

Fitting types

Support bracket

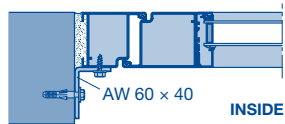

Plugs for metal frame for brickwork

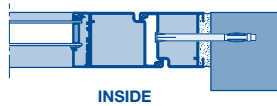

Tapping screw with countersunk head
B 6.3 x 80 for steel subframes

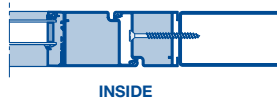

Chamfered Bottom Profile

Fitting example rolling shutter DD

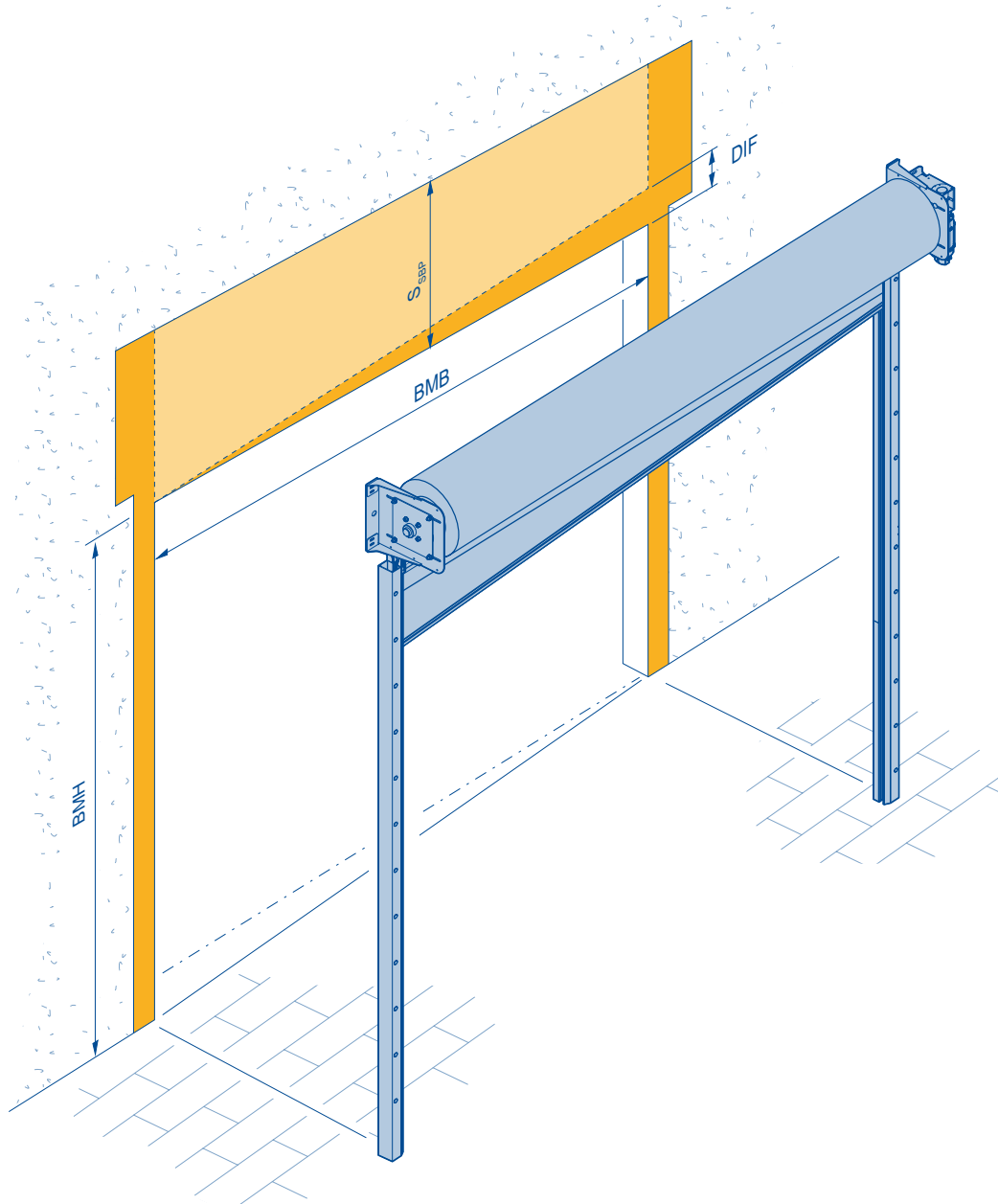

- BMB** = Door width ordering size
- BMH** = Door height ordering size
- DIF** = Difference dimension
- S** = Required headroom
- S_{SBP}** = Required headroom for door with chamfered bottom profile

Chamfered bottom profile

Chamfered bottom profile, single-skinned

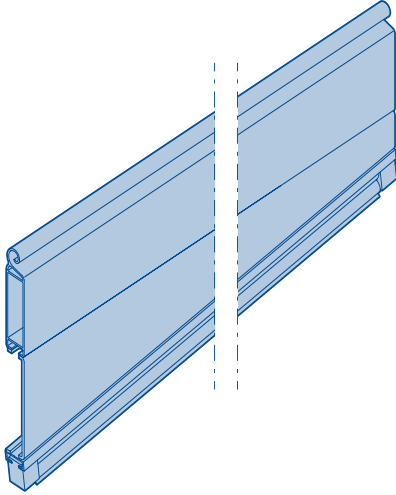

Note:

- Door width \leq 5800 mm
- Max. difference dimension 525 mm
- $S_{SBP} = S +$ difference dimension + 50 (observe passage height loss for SB rolling shutter / rolling grille and TGT rolling shutter / rolling grille)
- For SB rolling shutters / rolling grilles and TGT rolling shutters / rolling grilles only with Decotherm S curtain
- Can be combined with lockable bottom profile ABP 1 and ABP 2
- Not in conjunction with accessory package S6

Chamfered bottom profile, single-skinned – with butt weld

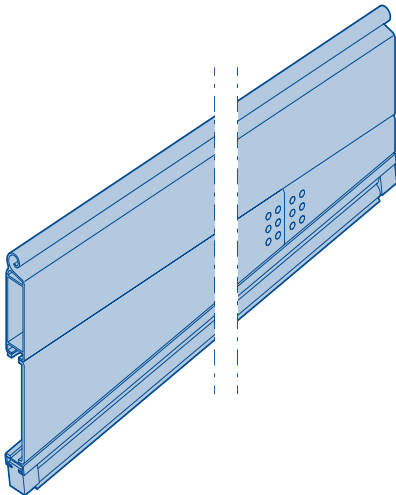

Note:

- Door width $>$ 5800 mm
- Max. difference dimension 525 mm
- $S_{SBP} = S +$ difference dimension + 50
- Can be combined with lockable bottom profile ABP 1 and ABP 2
- Cannot be combined with
 - Accessory package S6
 - Rolling grille SB / TGT

Chamfered bottom profile, double-skinned

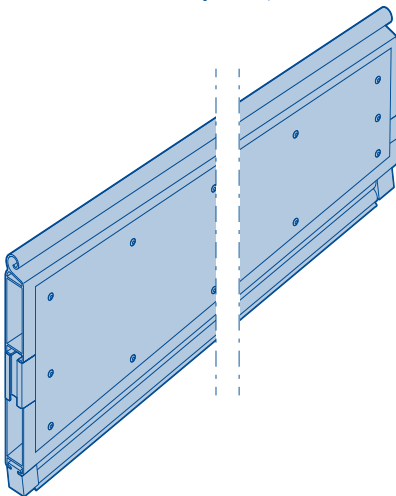

Note:

- Max. difference dimension 1000 mm
- $S_{SBP} = S +$ difference dimension
- Cannot be combined with
 - Lockable bottom profile ABP 1 and ABP 2
 - Accessory package S6
 - Rolling shutters / rolling grilles SB
 - Rolling shutters / rolling grilles TGT

Rolling Shutters SB / Rolling Grilles SB

Space requirements

Fitting example with grip handle actuation type

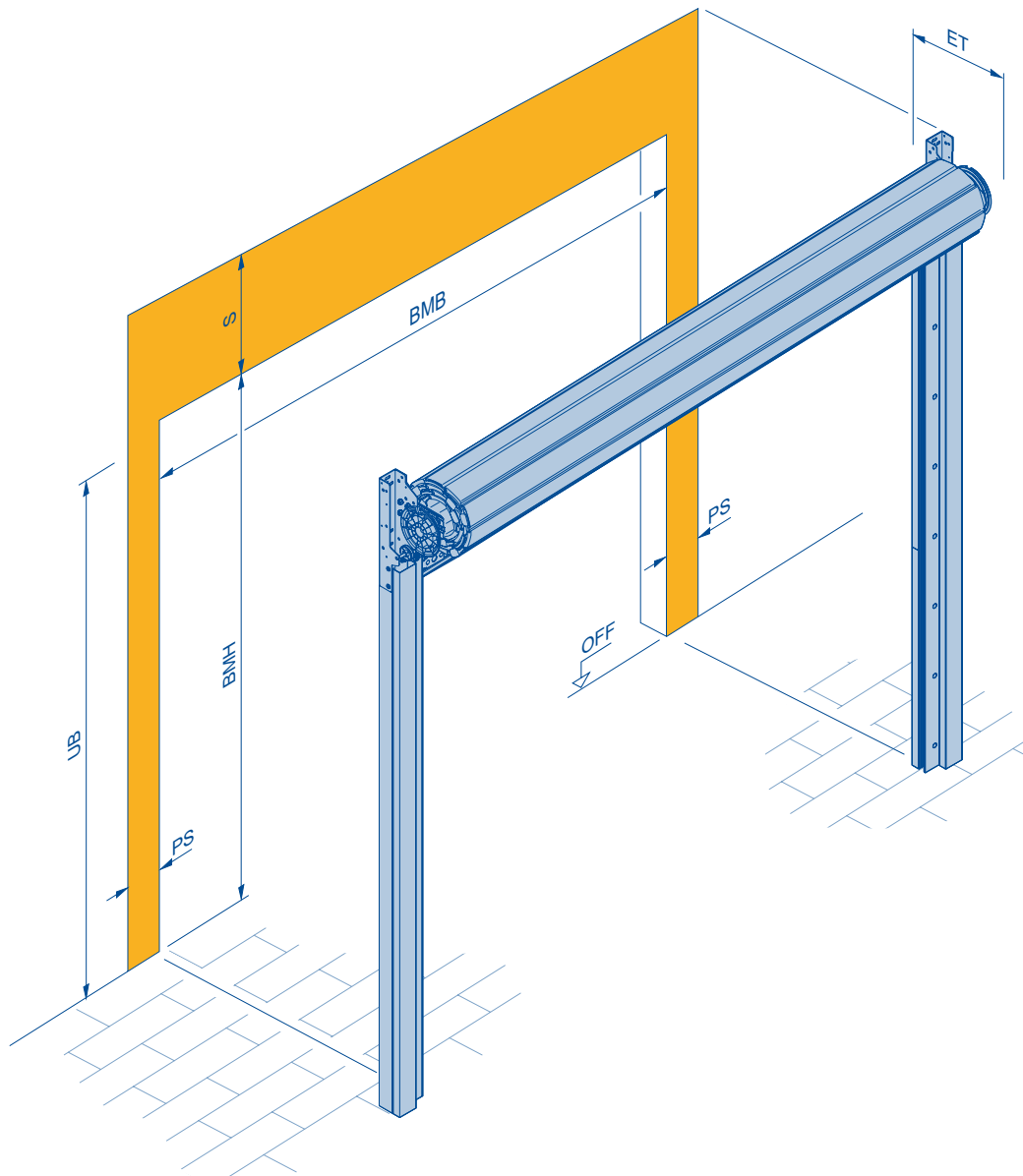

Actuation type	PS	UB
Grip handle	165	Door height + 75 mm
Chain Hoist	165	Door height - 75 mm
WA 250 R S4	165	Door height - 440 mm
WA 300 R S4	165	Door height - 440 mm
WA 300 AR S4	165 ¹⁾	Door height + 75 mm

1) with operator WA 300 AR S4 on operator side in the lintel area 265 mm, opposite side and guide rails unchanged 165 mm

BMB = Door width ordering size
BMH = Door height ordering size
S = Required headroom
ET = Fitting depth
PS = Side space requirement
UB = Bottom edge actuation
OFF = Top edge of finished floor

Note:

- The actuation type does not affect the following values:
 - Side space requirement **PS**¹⁾
 - Required headroom **S**
 - Available door sizes
- For doors with a height of more than 3,500 mm, we recommend the actuation type chain hoist or electrical operator.
- Maximum number of window laths
 - 4 laths: door width ≤ 2000 mm
 - 8 laths: door width > 2000 mm
- The minimum door width for window profiles is
 - 1245 mm for Decotherm S
 - 1750 mm for HR 120 A

Rolling Shutters SB / Rolling Grilles SB

Table of standard values / maximum wind loads

Table of standard values

Door height

4500	532	437	30	527*	432*	28	470	355	27			
4250	529	434	28	527*	432*	27	467	352	26			
4000	524	429	27	518	423	25	467	341	24			
3750	519	424	25	518	423	24	460	341	23			
3500	489	394	24	493	398	22	460	341	21	473	358	22
3250	484	389	22	485	390	21	460	335	20	470	355	21
3000	482	387	20	485	390	19	460	327	19	460	348	19
2750	475	380	19	477	382	18	460	324	17	460	348	18
2500	473	378	17	477	382	16	460	324	16	460	335	16
2250	465	370	16	468	373	15	460	317	14	460	325	15
	Decotherm S			HR 120 A HR 120 aero			HG-L			HG 75		

¹²³ = S (required headroom)

¹²³ = ET (minimum fitting depth)

¹² = Door opening time [s]

* = Only HR 120 A

Note:

- The required headroom **S** and the fitting depth **ET** do not depend on the door width or actuation type.
- For doors with trap guard PVSB, the required headroom **S** is increased to at least 490 mm, see page 17.
- The required headroom **S** is decreased by 75 mm for external rolling shutters with lockable bottom profile ABP 1/2 or SKS, see page 17.
- For some equipment combinations there is a loss of passage height, see page 17.
- The fitting depth **ET** is at least
 - 356 mm for doors with hand chain
 - 370 mm for doors with WA 250 R S4 or WA 300 R S4
 - 620 mm for doors with PVSB, see page 17
- Door widths
 - Max. 6000 mm: HG-L, HG 75
 - Max. 5000 mm: Decotherm S, HR 120 A
 - Max. 4000 mm: HR 120 aero
 - Min. 1750 mm: HR 120 A, HR 120 aero
 - Min. 1000 mm: Decotherm S, HG-L, HG 75
- Door heights:
 - Max. 4500 mm: Decotherm S, HR 120 A, HG-L
 - Max. 4000 mm: HR 120 aero
 - Max. 3500 mm: HG 75
 - Min. 2000 mm: all curtains
- All curtains as standard with wind lock or extraction retainers

Maximum wind loads and door widths

	Maximum possible door widths			
	Wind load class 4 (1.0 kN/m ² or 146 km/h)	Wind load class 3 (0.7 kN/m ² or 120 km/h)	Wind load class 2 (0.45 kN/m ² or 96 km/h)	Wind load class 1 (0.3 kN/m ² or 80 km/h)
Decotherm S	5000	–	–	–
HR 120 A	3250	4000	5000	–
HR 120 aero	2750	3250	4000	–

Note:

- Maximum wind load only for standard rolling shutters without window profiles and ventilation laths
- Wind load classes acc. to EN 12424

Rolling Shutters SB / Rolling Grilles SB

Side guide / lintel seal

Side guide FS 160 A

with spring chamber

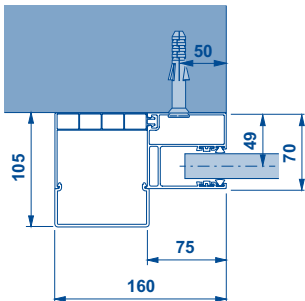

Note:

- Aluminium side guide with plastic spring chamber
- Spring chamber depending on curtain type and door size
 - only on the right side guide or the operator side
 - on the right and left side guide

without spring chamber

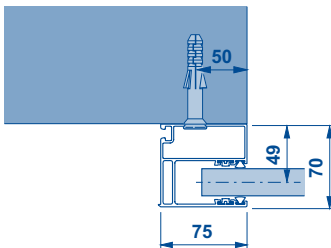

Lintel seal

SD2

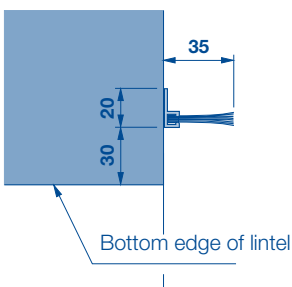

Note:

- Subject to a surcharge for SB rolling shutters
- SD2 for door widths ≤ 2500 mm
- SD3 for door widths > 2500 mm

SD3

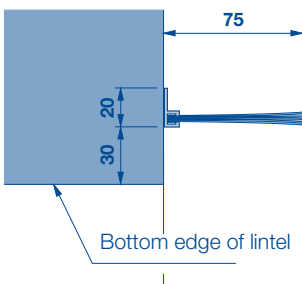

Rolling Shutters SB / Rolling Grilles SB

Support bracket / maximum load at the fixing point

Support bracket / maximum load at the fixing point

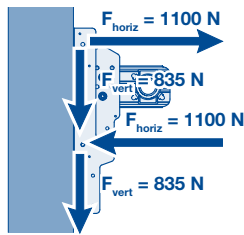
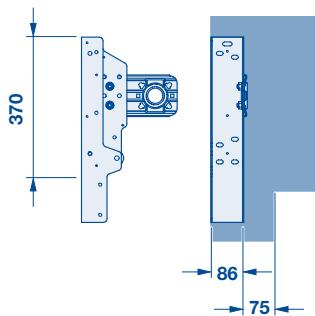

Minimum requirements for the building structure

Concrete

Strength class C 20 / 25

Thickness 140 mm

Standard EN 206-1

Steel

Strength class S235-JRG2

Thickness 5 mm

Standard EN 10027-1

Brickwork

Strength class 12 / mortar group II

Thickness 240 mm

Standard DIN 1053-1

Timber

Coniferous wood: C24 / quality category II

Thickness 120 × 120 mm

Standard DIN 1052 (EC5)

F_{horiz} = Horizontal force at the fixing point

F_{vert} = Vertical force at the fixing point

Rolling Shutters SB / Rolling Grilles SB

Actuation types

Actuation types

Grip handle

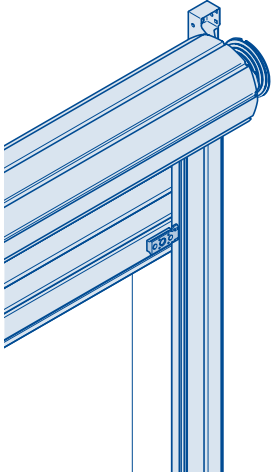

Note:

- No surcharge
- One handle each on the left and right of the interior bottom profile
- One handle on the left in the exterior bottom profile

Chain Hoist

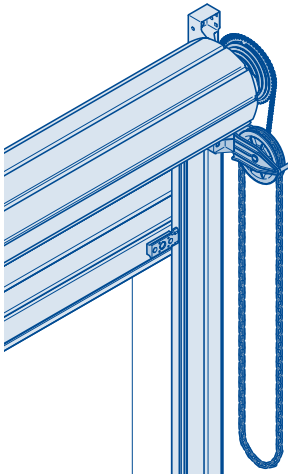

Note:

- Subject to surcharge
- No influence on
 - **PS**
 - **S**
 - Available door sizes
- Recommended for door sets with heights over 3500 mm

WA 250 R S4 / WA 300 R S4

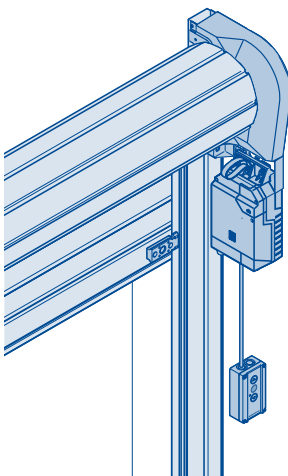

WA 300 AR S4

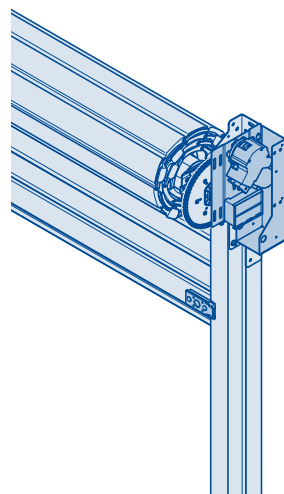

Note:

- Subject to surcharge
- No influence on
 - **PS** ¹⁾
 - **S**
 - Available door sizes
- Recommended for door sets with heights over 3500 mm
- A trap guard PVSB must be used with door systems with impulse operation and a door height ordering size below 2500 mm.

1) with operator WA 300 AR S4 on operator side in the lintel area 265 mm, opposite side and guide rails unchanged 165 mm

Rolling Shutters SB / Rolling Grilles SB

Trap guard PVSB / loss of passage height

Trap guard PVSB

Trap guard PVSB with small sheet cover

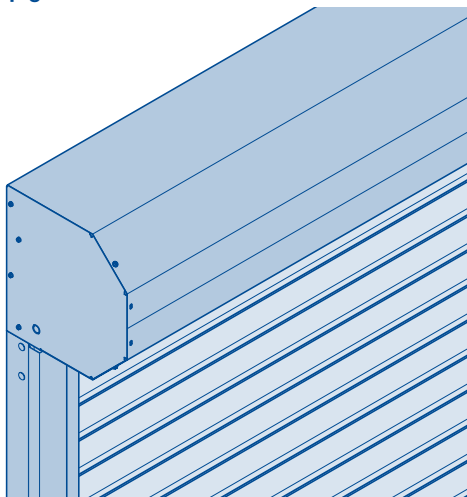

Trap guard PVSB with large sheet cover

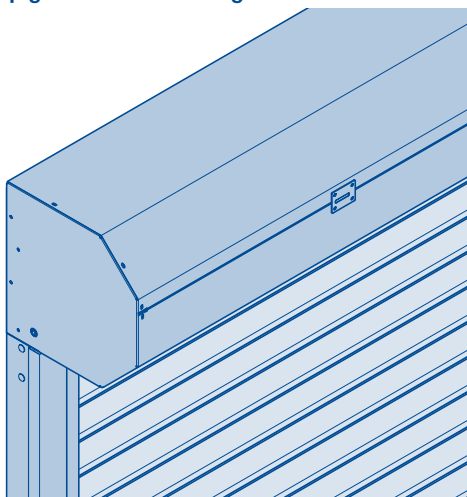

Note:

- Subject to surcharge
- The trap guard PVSB with small sheet cover is used for:
 - Rolling shutters SB with door heights ≤ 3000 mm
 - Rolling grille SB
- The trap guard PVSB with large sheet cover is used for:
 - Rolling shutters SB with door heights > 3000 mm
- The trap guard PVSB has no effect on **PS**.
- The required headroom **S** is at least:
 - 490 mm for PVSB with small sheet cover
 - 545 mm for PVSB with large sheet cover
- The fitting depth **ET** is at least:
 - 620 mm for PVSB with small sheet cover
 - 700 mm for PVSB with large sheet cover
- The combination of the trap guard PVSB with the lockable bottom profile ABP 1/2 lowers the passage height.
- Chamfering of the steel cover always towards the bottom

Loss of passage height

Internal rolling shutter example

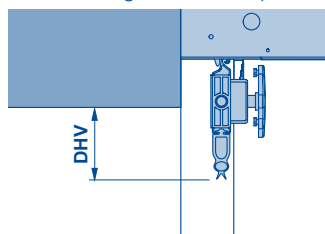

External rolling shutter example

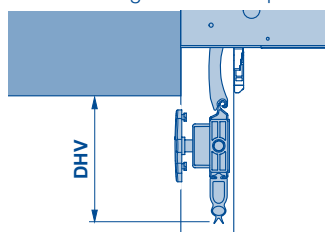

Version	Equipment	Loss of passage height (DHV)	Change of the required headroom
Internal rolling shutter	PVSB + shootbolt:	50	0
	PVSB + ABP 1/2	50	0
	PVSB + SKS	50	0
	Chamfered bottom profile	50 + difference dimension	0
	Chamfered bottom profile + PVSB + shootbolt / ABP / SKS	100 + difference dimension	0
External rolling shutter	ABP 1/2	125	-75
	SKS	75	-75
	Chamfered bottom profile	50 + difference dimension	0
	Chamfered bottom profile + ABP 1/2	175 + difference dimension	0
	Chamfered bottom profile + SKS	125 + difference dimension	0

Rolling Shutters TGT / Rolling Grilles TGT

Space requirements

Fitting example with trap guard PVTGT

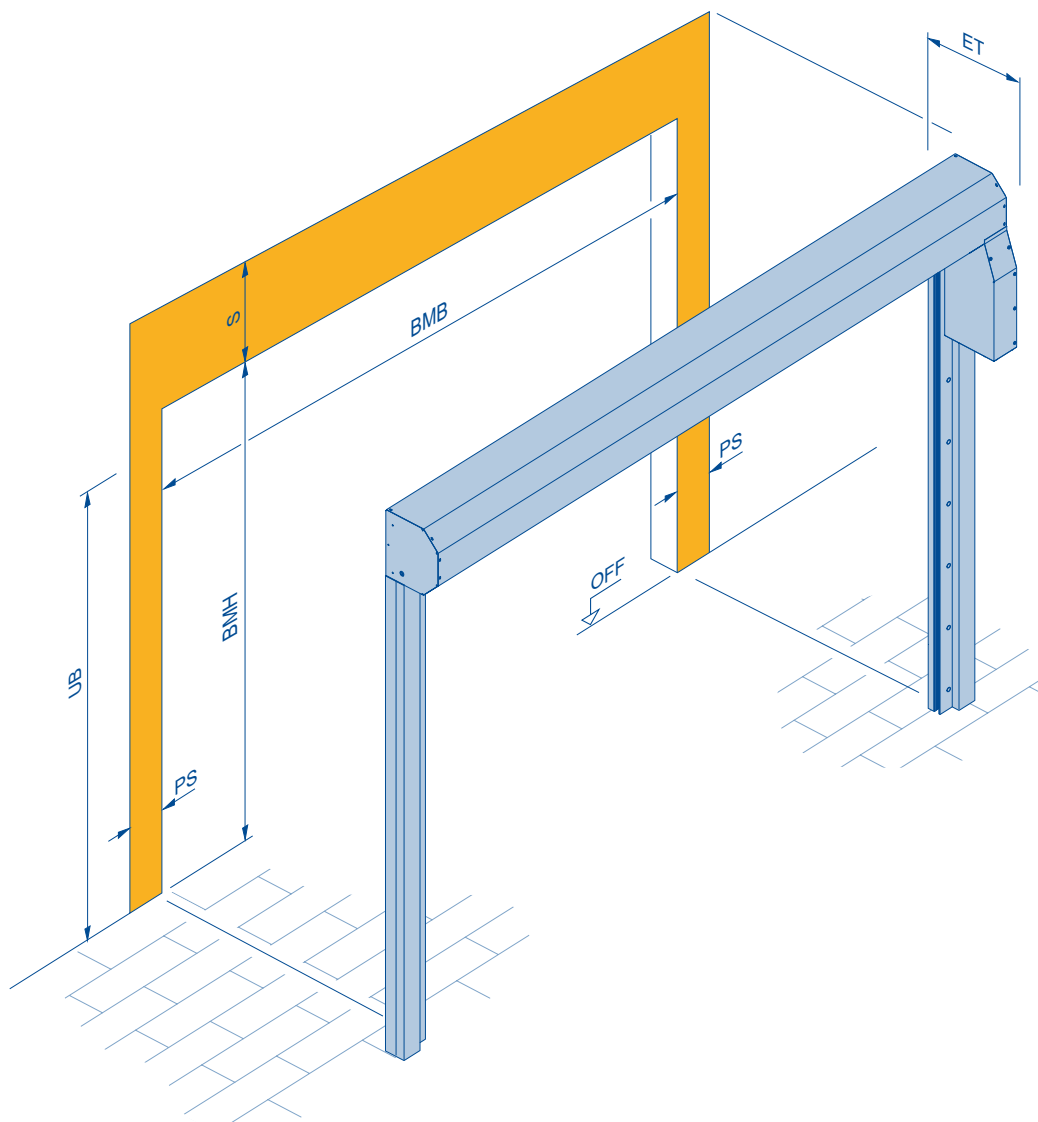

Actuation type	PS	UB
WA 300 R S4	165	Door height – 440 mm

BMB = Door width ordering size
BMH = Door height ordering size
ET = Fitting depth
OFF = Top edge of finished floor
PS = Side space requirement
S = Required headroom
UB = Bottom edge actuation

Note:

- The actuation type does not affect the following values:
 - Side space requirement **PS**
 - Required headroom **S**
 - Available door sizes
- Door widths
 - Max. 6000 mm: HG-L (from 01.06.2016)
 - Max. 5000 mm: Decotherm S
 - Min. 1000 mm: all curtains
- Door heights for all curtains:
 - Max. 2400 mm
 - Min. 2000 mm
- Maximum number of window laths:
 - 4 laths: door width ≤ 2000 mm
 - 8 laths: door width > 2000 mm
- The minimum door width for window profiles is 1245 mm.

Rolling Shutters TGT / Rolling Grilles TGT

Table of standard values / side guide / lintel seal / support bracket / maximum load at the fixing point / loss of passage height

Table of standard values

Door height

2400	365	370	14	335	370	16
2250	360	370	13	330	370	14
2000	355	370	12	325	370	13
	Decotherm S			HG-L		

123 = S (required headroom)

123 = ET (minimum fitting depth)

12 = Door opening time [s]

Note:

- For doors with trap guard PVTGT, the required headroom **S** is increased to
 - at least 380 mm: Decotherm S
 - at least 350 mm: HG-L
- The fitting depth **ET** for doors with PVTGT trap guards is
 - at least 620 mm: Decotherm S
 - at least 600 mm: HG-L
- Required headroom **S** and fitting depth **ET** are independent of the door width.
- All curtains as standard with wind lock or extraction retainers
- Chamfering of the steel cover with PVTGT always towards the bottom

Side guide FS 160 A

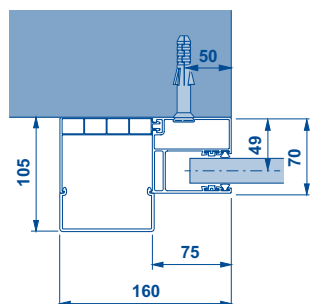

Note:

- Aluminium side guide with plastic spring chamber
- Spring chamber depending on curtain type and door size
 - only on the right side guide or the operator side
 - on the right and left side guide

Lintel seal SD2/SD3

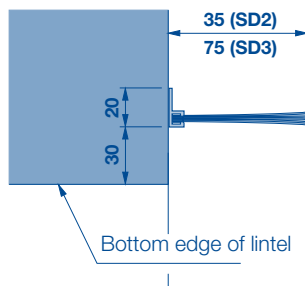

Note:

- Subject to a surcharge for TGT rolling shutters
- SD2 for door widths ≤ 2500 mm
- SD3 for door widths > 2500 mm

Support bracket / maximum load at the fixing point

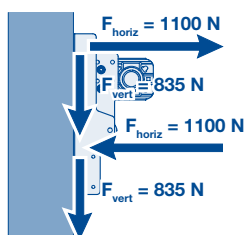
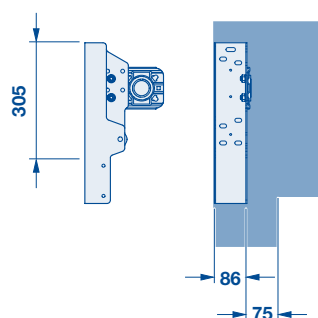

Minimum requirements for the building structure

Concrete

Strength class C 20 / 25

Thickness 140 mm

Standard EN 206-1

Steel

Strength class S235-JRG2

Thickness 5 mm

Standard EN 10027-1

Brickwork

Strength class 12 / mortar group II

Thickness 240 mm

Standard DIN 1053-1

Timber

Coniferous wood: C24 / quality category II

Thickness 120 × 120 mm

Standard DIN 1052 (EC5)

F_{horiz} = Horizontal force at the fixing point

F_{vert} = Vertical force at the fixing point

Loss of passage height

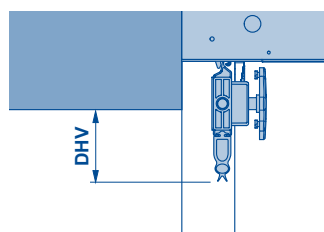

Version	Equipment	Loss of passage height (DHV)	Change of the required headroom
Internal rolling shutter / external rolling shutter	ABP	125	0
	Chamfered bottom profile	50 + difference dimension	0
	Chamfered bottom profile + ABP	175 + difference dimension	0

Rolling Shutters DD / Rolling Grilles DD

Space requirements

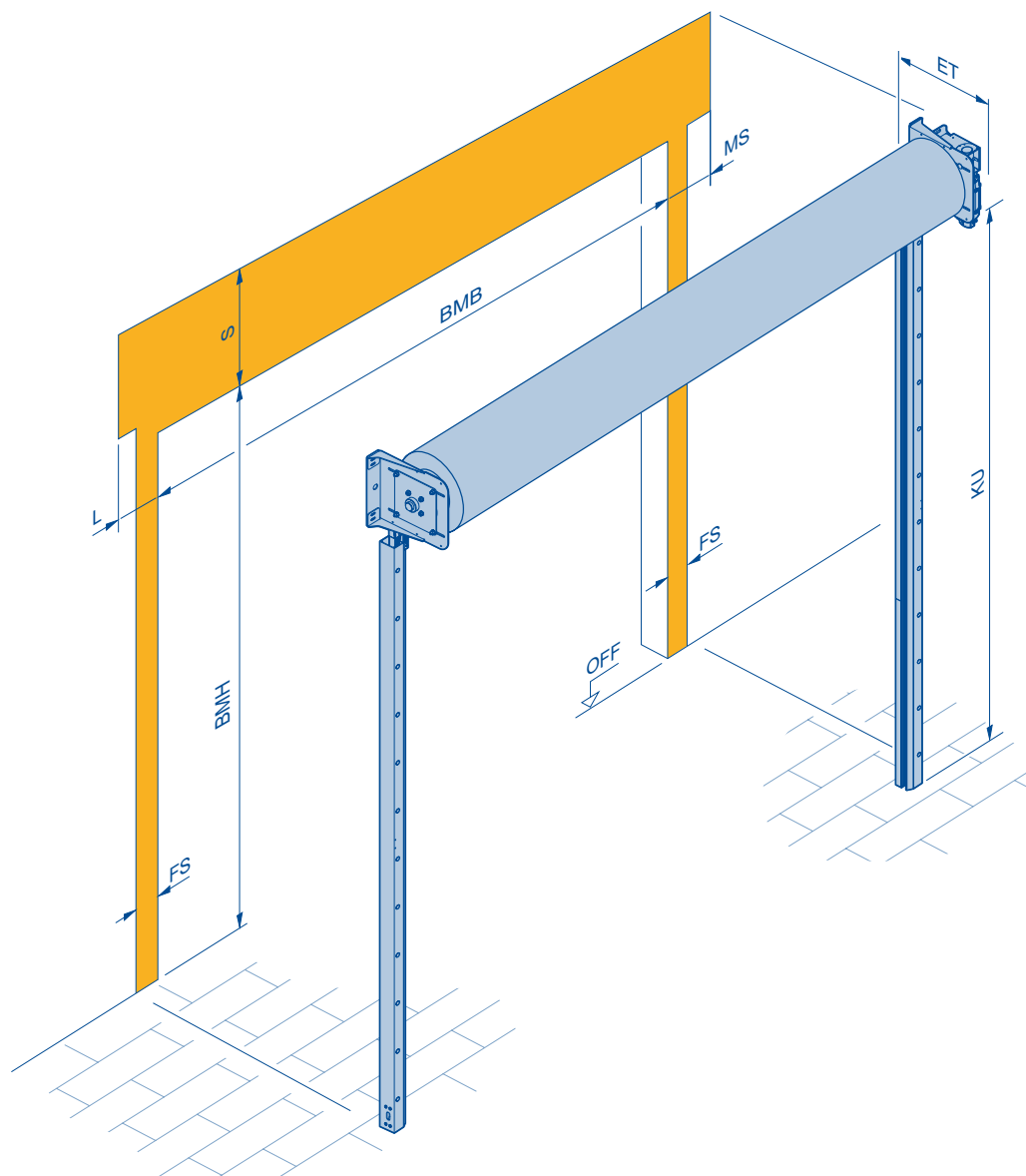

L	MS	FS	KU	L	MS	FS	KU
for doors with $ET \leq 415$				for doors with $ET > 415$			
160	260	80 ¹⁾	⁵⁾	180	280	80 ¹⁾	⁵⁾
240 ²⁾	420 ²⁾			260 ²⁾	440 ²⁾		
160 ³⁾	290 ³⁾	103 ³⁾	⁵⁾	180 ³⁾	290 ³⁾	103 ³⁾	⁵⁾
240 ⁴⁾	450 ⁴⁾			260 ⁴⁾	450 ⁴⁾		

- 1) Standard fitting without a bracket
- 2) Space requirement for dismantling from the side
- 3) Space requirement in conjunction with accessory package S6
- 4) Space requirement for dismantling from the side in conjunction with accessory package S6
- 5) Dimension depends on a door size

BMB = Door width ordering size
BMH = Door height ordering size
ET = Fitting depth see tables from page 28
FS = Sideroom for side guide
KU = Support bracket dimension bottom

Note:

- The fitting example shows the arrangement of the operator from the right as seen from the inside. An arrangement on the left is also available on request.
- For external rolling shutters, the operator side is determined from the outside.

L = Bearing side sideroom
MS = Motor side sideroom for direct drive operators
OFF = Top edge of finished floor
S = Required headroom see tables from page 28

Rolling Shutters DD / Rolling Grilles DD

Space requirement behind the lintel

Rolling shutter DD with suspended operator

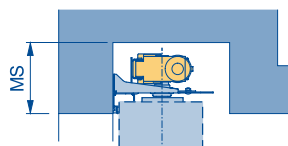
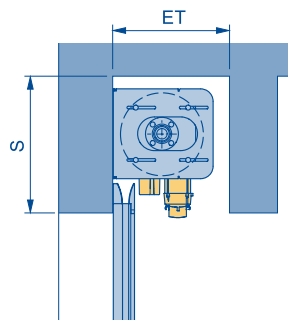

- S** = See Tables of Standard Values from page 28
ET = See Tables of Standard Values from page 28
MS = See page 20

Rolling shutter DD with horizontal operator

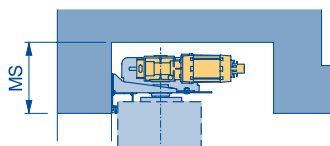
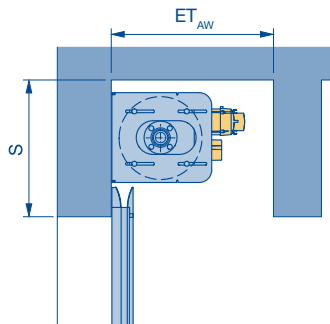

- S** = See Tables of Standard Values from page 28
ET_{AW} = Max. 950
MS = See page 20

Rolling shutter DD with vertical operator

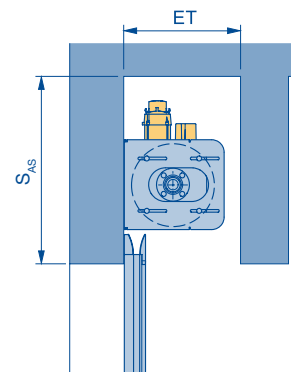

- S_{AS}** = Max. 1070
ET = See Tables of Standard Values from page 28
MS = See page 20

Rolling shutter DD with PVDD and VDD

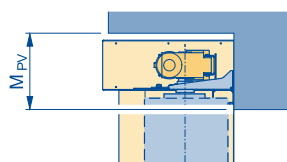
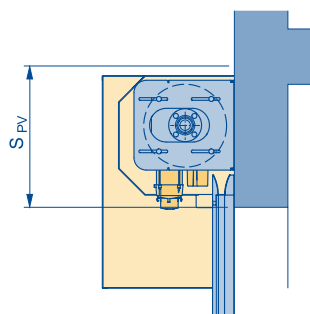

- S_{PV}** = $S + 75$
M_{PV} = 290 / 310³⁾

Rolling shutter DD with fascia panel

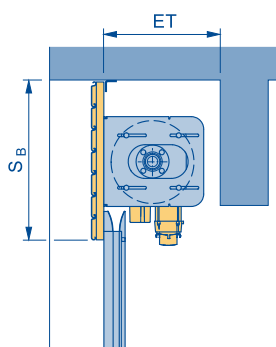

- S_B** = Observe the fitting dimensions of the profiles (see page 4)

General information:

- Please request **ET** for doors with special operators at Hörmann KG Dissen.

Rolling Shutters DD / Rolling Grilles DD

Side guide

FS 80 without support profile

Standard fitting

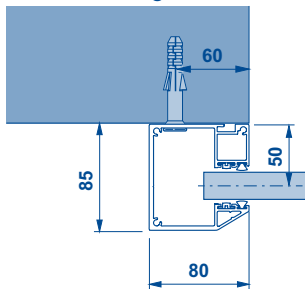

Angle fitting

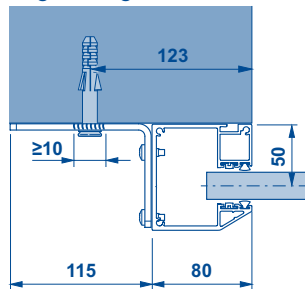

Note:

- For the number of support profiles see tables from 28
- Angle fitting
 - Optional
 - Fitting by welding possible
 - Not on brickwork
 - Not in conjunction with accessory package S6

FS 80 with support profile

Standard fitting

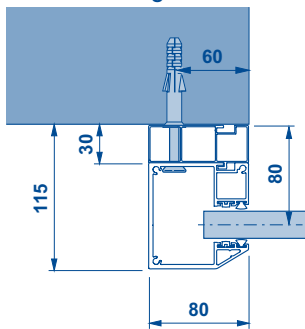

Angle fitting

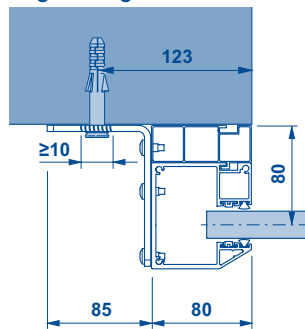

Note:

- For the number of support profiles see tables from 28
- Angle fitting
 - Optional
 - Fitting by welding possible
 - Not on brickwork
 - Not in conjunction with accessory package S6

FS 80 with two support profiles

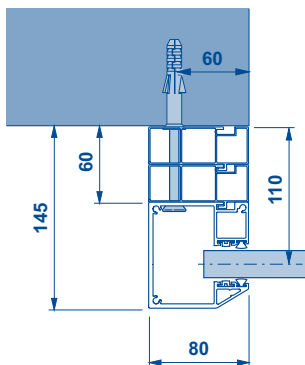

Note:

- For the number of support profiles see tables from 28
- Angle fitting not possible

Rolling Shutters DD / Rolling Grilles DD

Lintel seals / support brackets / Maximum loads at the fixing point

Lintel seals

SD3

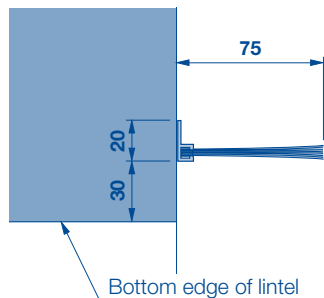

Note:

- For rolling shutters without support profile

SD4

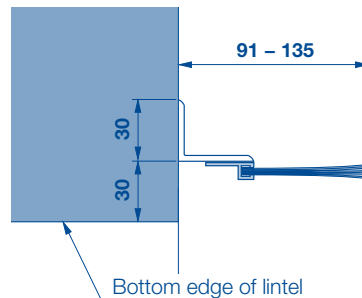

Note:

- For rolling shutter with a support profile
- Cover width adjustable

SD5

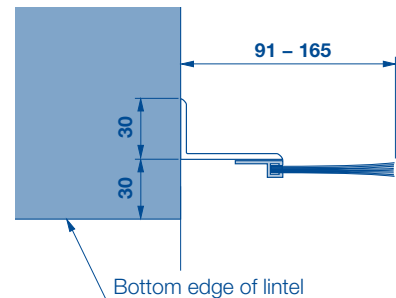

Note:

- For rolling shutters with two support profiles
- Cover width adjustable

Support brackets

Support bracket 40

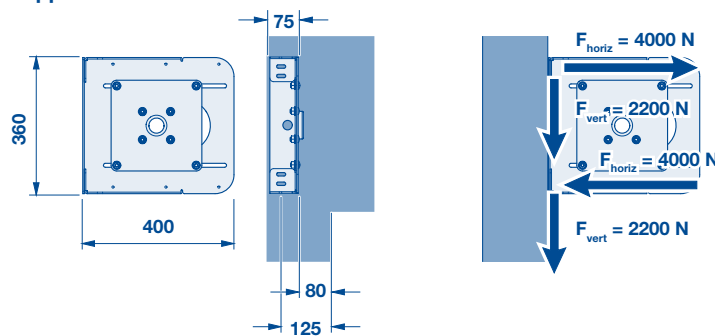

Note:

- Use depends on
 - Operator size
 - Barrel diameter

Support bracket 60

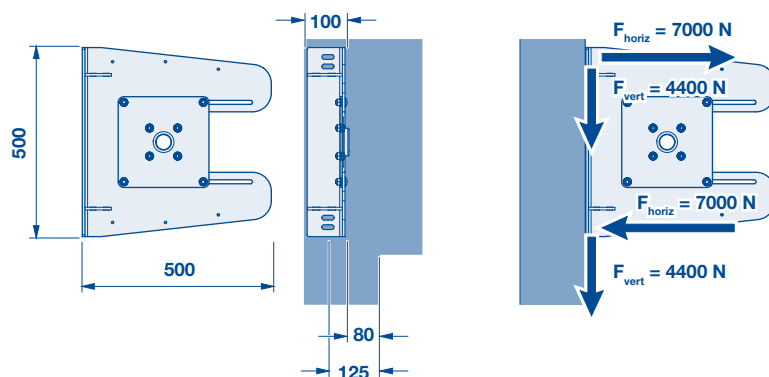

Note:

- Use depends on
 - Operator size
 - Barrel diameter

Minimum requirements for the building structure

Concrete

Strength class	C 20 / 25
Thickness	140 mm
Standard	EN 206-1

Steel

Strength class	S235-JRG2
Thickness	5 mm
Standard	EN 10027-1

Brickwork

Strength class	12 / mortar group II
Thickness	240 mm
Standard	DIN 1053-1

Timber

Coniferous wood:	C24 / quality category II
Thickness	120 × 120 mm
Standard	DIN 1052 (EC5)

Rolling Shutters DD / Rolling Grilles DD

Weld-on plates for support brackets / Fitting in the opening with additional posts

Weld-on plates for support brackets

Lightweight construction weld-on plates

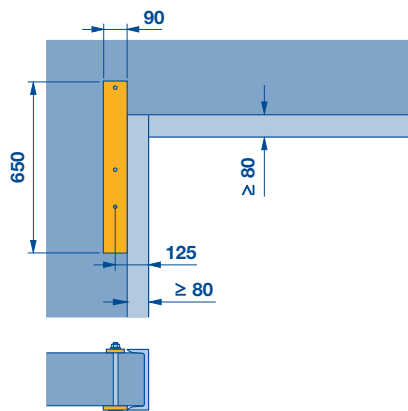

Steel construction weld-on plates

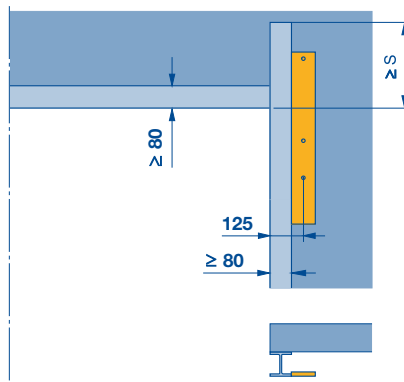

Note:

- For fixing by using a supporting lightweight construction, a subframe made of steel is required
- Weld-on plates are subject to surcharge
- For fitting by welding for side guides see page 22

Fitting in the opening with additional posts

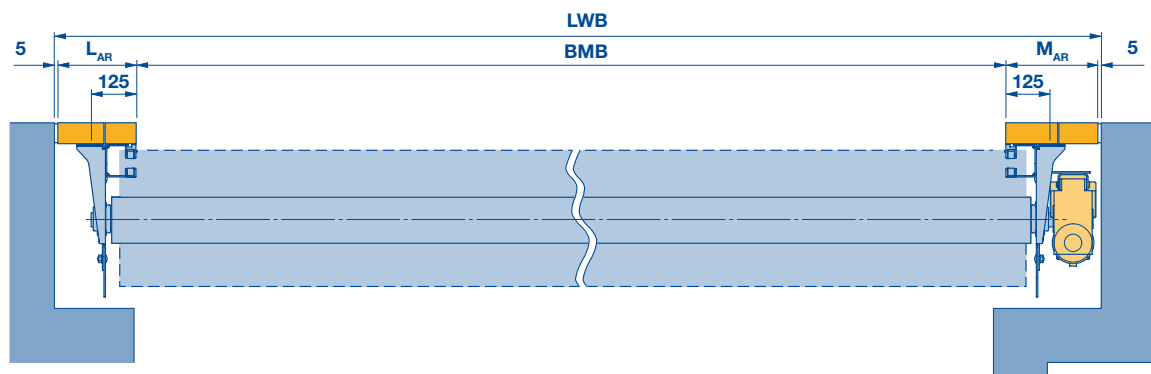

Additional posts available

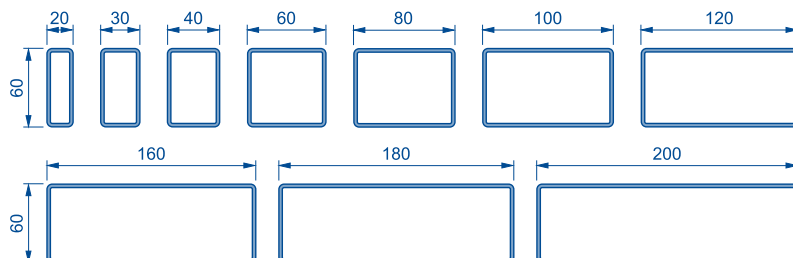

Note:

The width of the siderooms created with additional posts must be derived from the dimensions of the available additional posts.

- BMB** = Door width ordering size
- L_{AR}** = Bearing side sideroom with additional posts
- LWB** = Structural opening width
- M_{AR}** = Motor side sideroom for direct drive operators with additional posts

Rolling Shutters DD / Rolling Grilles DD

Break-in-resistant locks / maximum wind loads

Break-in-resistant locks

Shootbolt

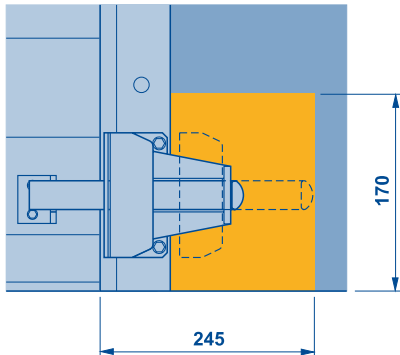

Note:

- Break-in-resistant locks subject to surcharge
- Lockable bottom profiles do not have any influence on the fitting space at the sides
- Lockable bottom profile not in conjunction with accessory package S6
- Shootbolts not for rolling grilles and exterior rolling shutters
- Position of the shootbolt either to the left, right or on both sides

Maximum wind loads and door widths

	Maximum possible door widths			
	Wind load class 4 (1.0 kN/m ² or 146 km/h)	Wind load class 3 (0.7 kN/m ² or 120 km/h)	Wind load class 2 (0.45 kN/m ² or 96 km/h)	Wind load class 1 (0.3 kN/m ² or 80 km/h)
Decotherm S	≤ 7250	≤ 9500	≤ 10000	–
HR 120 S	≤ 5500	≤ 6750	≤ 10000	≤ 12000
HR 120 A	≤ 4250	≤ 5500	≤ 7500	≤ 10250
HR 120 aero	≤ 3250	≤ 4250	≤ 5500	≤ 7500
HR 116 A	≤ 5500	≤ 8500	≤ 12000	–

Note:

- Wind load classes 3 and 4 optional
- Maximum wind load only for standard rolling shutters without window profiles and ventilation laths
- Wind load classes acc. to EN 12424

Rolling Shutters DD / Rolling Grilles DD

Trap guard / curtain cover PVDD without VDD

Fitting example with operator position vertical to the bottom

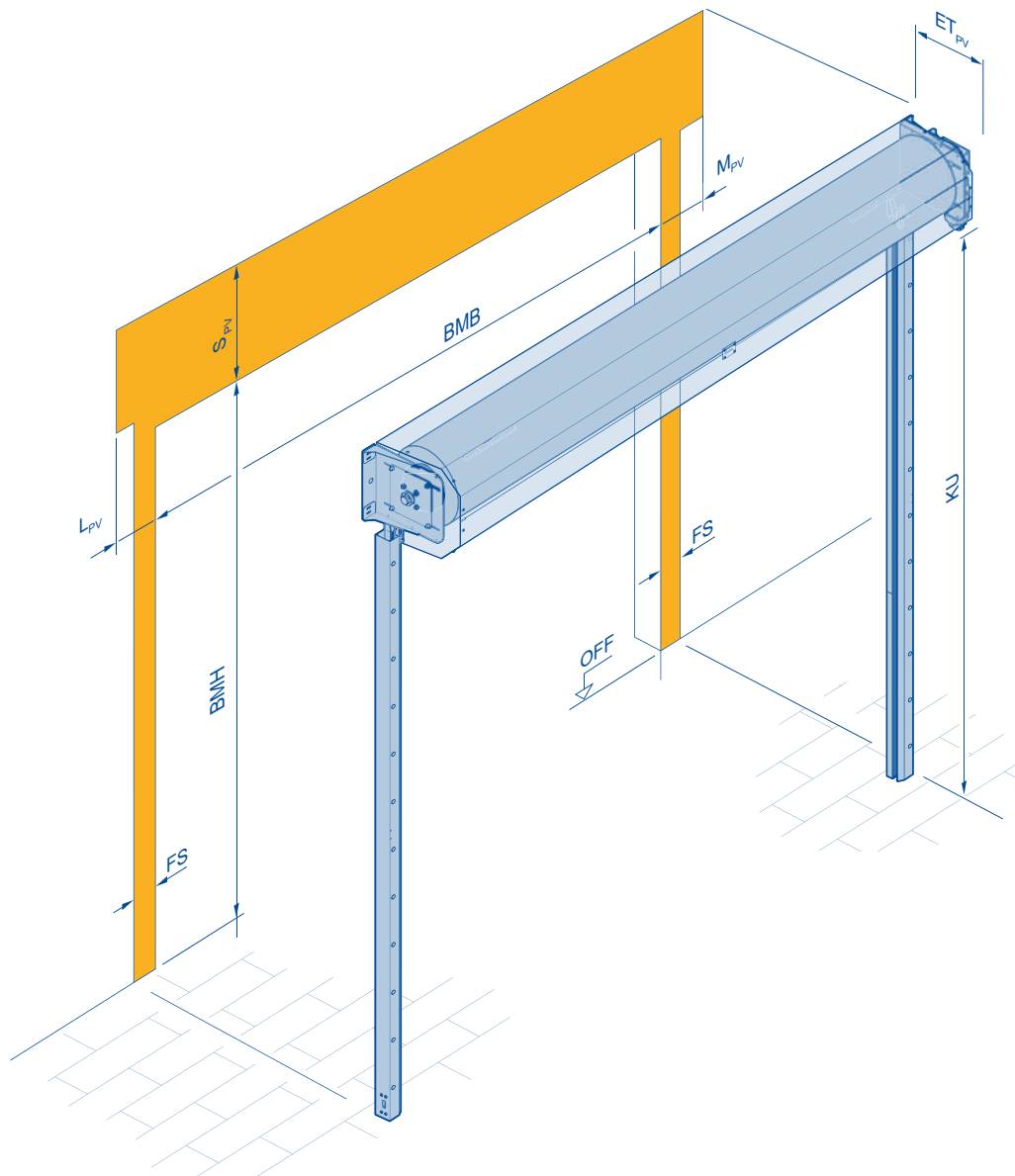

Application range:

Door systems with impulse control and door ordering height less than 2500 mm.

BMB	= Door width ordering size
BMH	= Door height ordering size
ET_{pv}	= Minimum fitting depth for doors with PVDD
FS	= Sideroom for side guide
KU	= Support bracket dimension bottom
L_{pv}	= Bearing side sideroom for doors with PVDD
M_{pv}	= Operator side sideroom for doors with PVDD
OFF	= Top edge of finished floor
S	= Required headroom see tables from page 28
S_{pv}	= Required headroom for doors with PVDD

Note:

- PVDD without VDD does not affect the sideroom:
 - **L_{pv} = L** (see page 20)
 - **M_{pv} = MS** (see page 20)
- **S_{pv} = S + 75** (see tables from page 28)
- **ET_{pv} = max. 705**
- PVDD without VDD complies with the legal requirements of a trap guard
- Sheet always chamfered towards the bottom
- No reduction of the clear passage height

Rolling Shutters DD / Rolling Grilles DD

Trap guard / curtain cover PVDD with VDD

Fitting example with operator on the right side

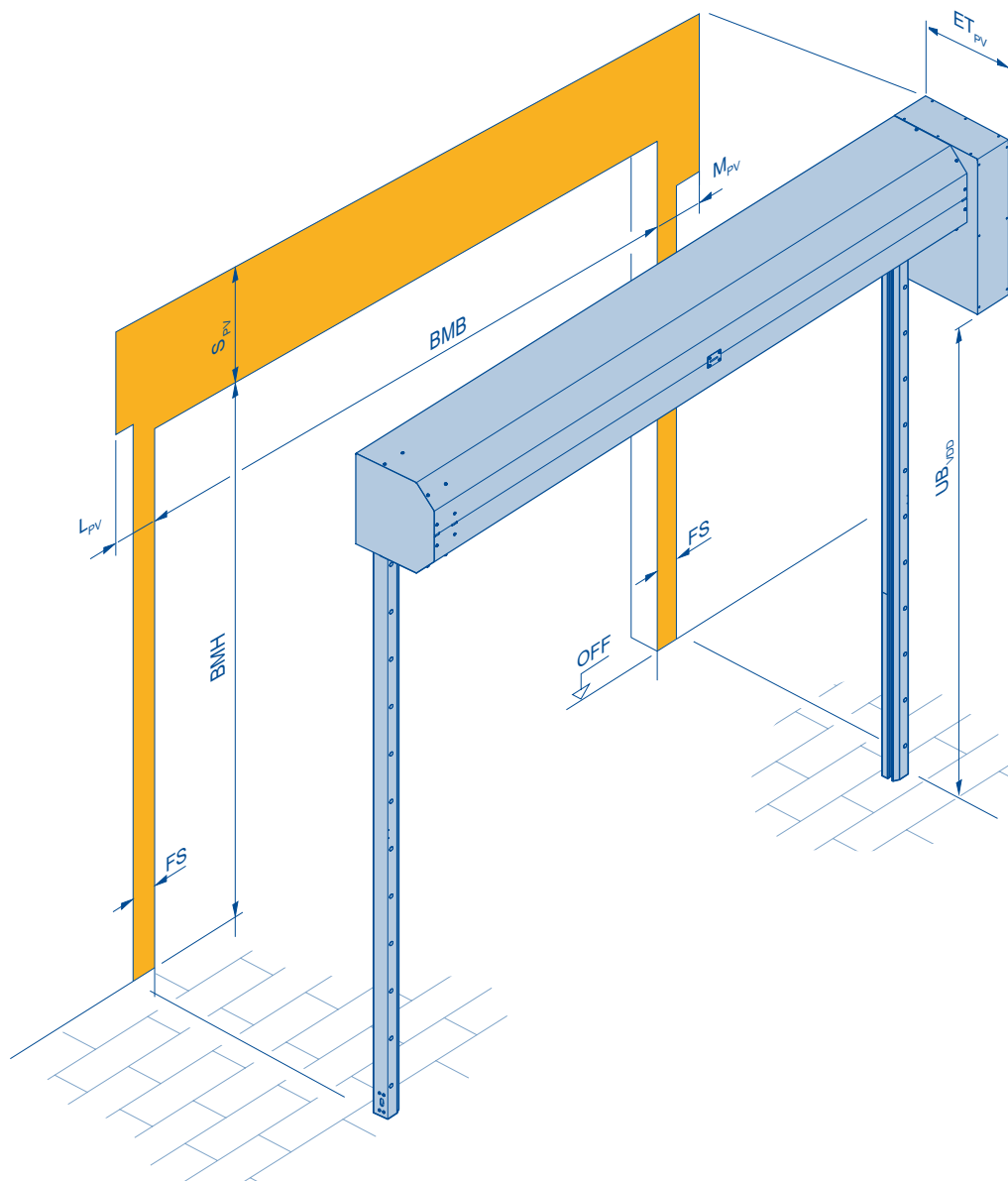

Application range:

Door systems requiring weather or contamination protection.

M_{PV}	L_{PV}	UB_{VDD}
290	195	Door height – 400
310 ¹⁾	195 ¹⁾	Door height – 400 ¹⁾

1) Space requirement in conjunction with accessory package S6

BMB = Door width ordering size
BMH = Door height ordering size
ET_{PV} = Minimum fitting depth for doors with PVDD
FS = Sideroom for side guide
L_{PV} = Bearing side sideroom for doors with PVDD
M_{PV} = Operator side sideroom for doors with PVDD
OFF = Top edge of finished floor
S = Required headroom see tables from page 28
S_{PV} = Required headroom for doors with PVDD
UB_{VDD} = Bottom edge actuation with VDD

Note:

- $S_{PV} = S + 75$ (see tables from page 28)
- $ET_{PV} = \text{max. } 705$
- PVDD with VDD complies with the legal requirements of a trap guard
- Sheet always chamfered towards the bottom
- Operator position always vertical to the bottom
- No reduction of the clear passage height
- For external rolling shutters:
 - Fitting of the controller and SKS housing on the rear side of the end wall
 - For changes to the profile views, see page 4



Rolling Shutter DD

Table of standard values

Decotherm S with accessory package S6

Door height		Opening time [s] DD40.40															
		Opening time [s] DD17.60 / DD25.60															
8500	850	636														--	12
8250	819	625														--	12
8000	819	625														--	12
7750	819	625	625													--	12
7500	819	625	625													--	12
7250	774	600	600	600	600											--	12
7000	770	596	596	596	596											--	12
6750	770	596	596	596	596	596										--	12
6500	770	596	596	596	596	596	596									--	11
6250	770	596	596	596	596	596	596	596								--	11
6000	769	595	595	595	595	595	595	595	595							8	11
5750	729	575	575	575	575	575	575	575	575	575						8	11
5500	729	575	575	575	575	575	575	575	575	575	575					8	11
5250	729	575	575	575	575	575	575	575	575	575	575	575				8	11
5000	699	483	565	565	565	565	565	565	565	565	565	565	565	565	565	8	11
4750	663	467	549	549	549	549	549	549	549	549	549	549	549	549	549	8	11
4500	657	461	461	543	543	543	543	543	543	543	543	543	543	543	543	8	10
4250	657	461	461	461	543	543	543	543	543	543	543	543	543	543	543	7	10
4000	657	461	461	461	543	543	543	543	543	543	543	543	543	543	543	7	9
3750	657	461	461	461	461	543	543	543	543	543	543	543	543	543	543	7	9
3500	619	443	443	443	443	443	525	525	525	525	525	525	525	525	525	7	9
3250	619	443	443	443	443	443	443	525	525	525	525	525	525	525	525	7	--
3000	619	443	443	443	443	443	443	443	525	525	525	525	525	525	525	6	--
2750	619	443	443	443	443	443	443	443	443	525	525	525	525	525	525	6	--
	2250	2500	2750	3000	3250	3500	3750	4000	4250	4500	4750	5000					

Door width

Operator
DD40.40
DD25.60
DD17.60

123 = S (required headroom)

123 = ET (fitting depth)

- Note:**
- All standard values only apply to standard version doors.
 - In conjunction with accessory package S6, number of support profiles is always 1
 - Minimum door width 1000 mm

Notes

Notes

Notes

Hörmann: Quality without Compromise



Hörmann KG Amshausen, Germany



Hörmann KG Antriebstechnik, Germany



Hörmann KG Brandis, Germany



Hörmann KG Brockhagen, Germany



Hörmann KG Dissen, Germany



Hörmann KG Eckelhausen, Germany



Hörmann KG Freisen, Germany



Hörmann KG Ichttershausen, Germany



Hörmann KG Werne, Germany



Hörmann Genk NV, Belgium



Hörmann Alkmaar B.V., Netherlands



Hörmann Legnica Sp. z o.o., Poland



Hörmann Beijing, China



Hörmann Tianjin, China

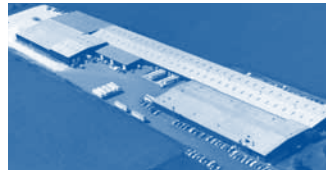

Hörmann LLC, Montgomery IL, USA



Hörmann Flexon LLC, Burgettstown PA, USA

Hörmann is the only manufacturer worldwide that offers you a complete range of all major building products from one source. We manufacture in highly-specialised factories using the latest production technologies. The close-meshed network of sales and service companies throughout Europe, and activities in the USA and China, make Hörmann your strong partner for first-class building products, offering "Quality without Compromise".

GARAGE DOORS
OPERATORS
INDUSTRIAL DOORS
LOADING EQUIPMENT
HINGED DOORS
DOOR FRAMES

